

INDUSTRIAL WEIGHING SOLUTION



Rear display



Battery operation

SW-1A

Smart Weighing Scale

- Battery Operation
- Compact Design & Easy Operating
- 25mm LCD Display
- Limit Function
- Counting Function



CAS

SW-1A

Accurate counting function

- The SW-1A has a simple counting and limit function for quality product management. It is great for use in manufacturing, parts shops, hardware stores etc.



Used anywhere with battery power

- SW Series is operated by an AC adapter or alkaline batteries. Its compact design is great for use anywhere.



Clear and Highly legible LCD display

- SW-1 Series has a 25mm large LCD display and uses 6 highly legible digits.



DIMENSIONS

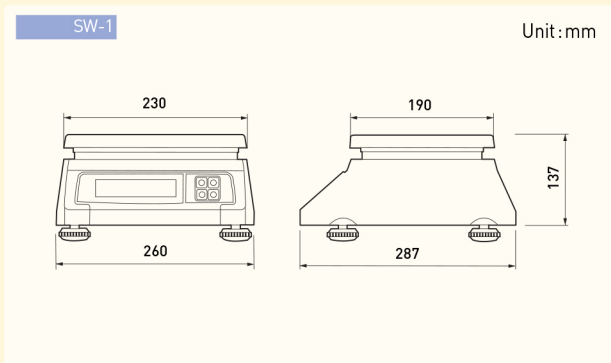

Model	SW-1A			
Max. capacity (kg)	3	6	15	30
Readability	0.1	0.2	0.5	1
Internal resolution	1/600000			
External resolution	1/30000			
Display digit	6 digit			
Display type	LCD Back light			
Battery life	Approx 400 hours (alkaline battery)			
Power	Dry battery (6pcs) 9V DC adapter			
Operating temperature	-10°C ~ +40°C			
Platter size (mm)	230(W)x190(D)			
Dimensions (mm)	260(W)x287(D)x137(H)			
Product weight	2.8			

OPTIONS

- Rear display (Dual display)
- AC adapter (9V/300mA)
- Stainless steel platter / Fish tray
- Dust protection cover



Fish tray ▲



Stainless steel platter ▲